

BLOWER HAVA KİLİDİ

Blower Air Lock
Шлюзовый Затвор Блвера

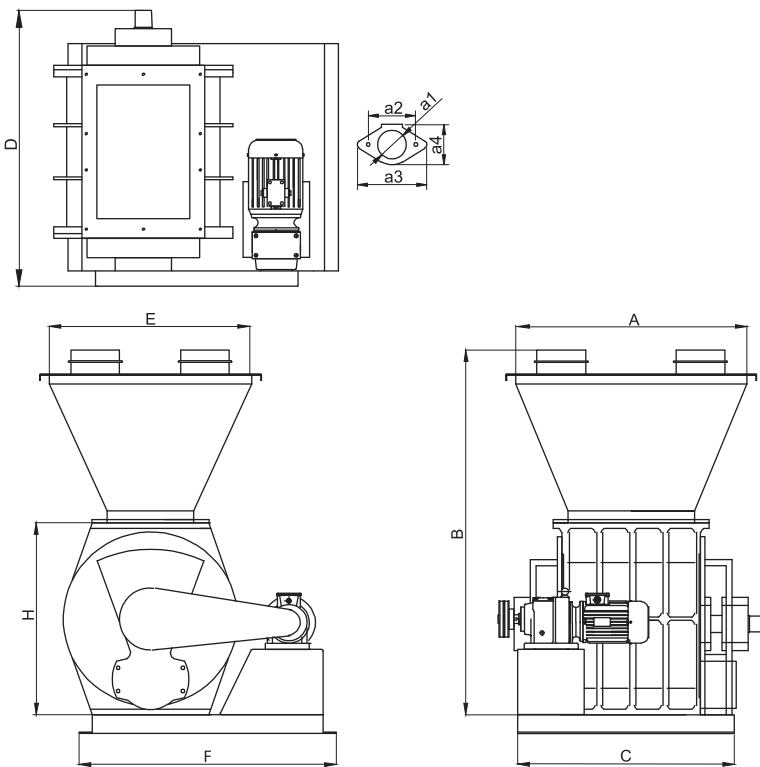

Type	Technical Features			Dimensions (mm)										
	Capacity (m ³ /h)	Motor (kW)	Shaft Dia (Ø)	A	B	C	D	E	F	H	a1	a2	a3	a4
ZBHK 200	0,37	4	28	350	700	275	540	370	230	330	57	110	160	80
ZBHK 250	0,55	10	28	450	750	375	600	400	260	380	70	135	166	100
ZBHK 320	0,55	22,7	42	700	900	550	700	450	750	445	100	160	210	132
ZBHK 450	0,75	51	42	800	1000	590	880	550	810	570	120	195	245	150
ZBHK 500	1,5	91	55	900	1275	640	1000	700	890	666	175	233	267	267

Maximum capacity has been calculated according to 65% occupancy rate